

CX-Series ARINC 600 Enclosure

- 2 thru 12 MCU (per ARINC 600)
- Lightweight aluminum construction (5052 H32)
- Ventilated design for convection cooling
- Removable top cover for equipment mounting
- Integrated front panel with fixed handles and mounting hooks
- Suitable for airborne electronics, high tolerance product
- Removable front and rear panels for easy access
- Stock, stock-to-build availability

Churchill Corporation, Inc.
344 Franklin St.
PO Box 761038
Melrose, MA 02176-0907

Tel: 781-665-4700

Toll Free 1-800-225-3932

Fax: 781-662-5291

sales@atrbox.com

www.atrbox.com

CX-Series ARINC 600 Enclosure

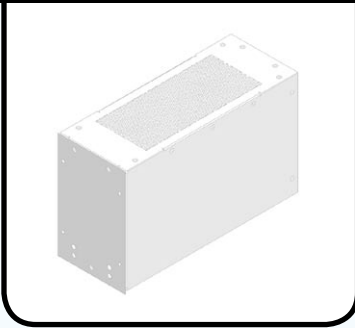

Part	Material
Chassis Wrap	.063" Alum
Chassis Top	.063" Alum
Chassis Back	.063" Alum
Front Panel	.125" Alum

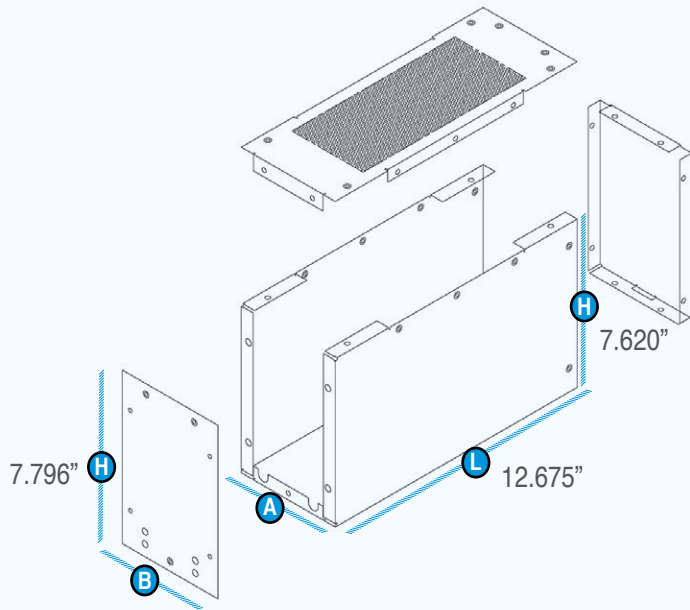

DIMENSIONS / FORM FACTOR

SIZE	2MCU	3MCU	4MCU	5MCU	6MCU	7MCU
Code	02	03	04	05	06	07
A	2.25"	3.56"	4.88"	6.19"	7.50"	8.79"
B	2.33"	3.64"	4.96"	6.27"	7.58"	8.87"
SIZE	8MCU	9MCU	10MCU	11MCU	12MCU	
Code	08	09	10	11	12	
A	10.09"	11.39"	12.69"	13.99"	15.29"	
B	10.17"	11.47"	12.77"	14.07"	15.37"	

ORDER CODE

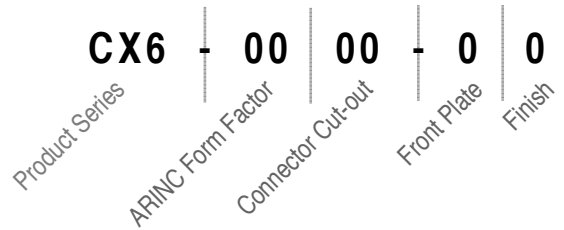

CONNECTOR CUT-OUTS

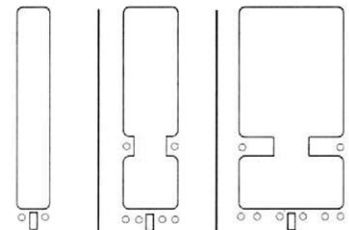

SHELL SIZE:	1	2	3
CODE:	C1	C2	C3

FRONT PLATE

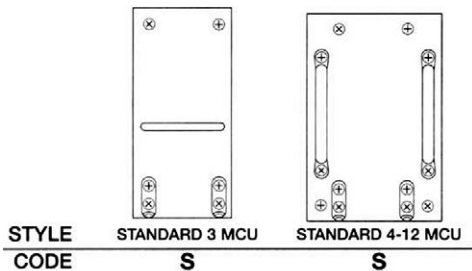
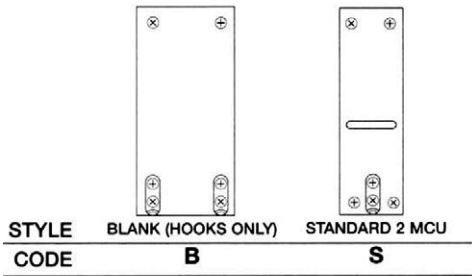

FINISH

CODE	DESCRIPTION
0	None
1	Black Wrinkle
2	Black Polane
3	Orange (Per MIL-STD 595)
00000	Per MIL-STD 595

